



**MOTOROLA**

**INSTALLATION INSTRUCTIONS**

**REPLACEABLE PUSHBUTTON**

**RETROFIT KIT FOR MCS 2000**

**MODEL I CONTROL HEAD**

**MOTOROLA KIT NUMBER REX4460( )**

---

**Introduction**

*NOTE:* The empty parentheses at the end of the kit numbers cited in this document stand for the alphabetical characters (A, B, etc.) that denote the revision levels of the kits. The revision levels of the kits may change from time to time without affecting the validity of these installation instructions.

The control heads on earlier production MCS 2000 Mobile Radios did not have the replaceable control head pushbutton feature. The replaceable pushbutton retrofit kit converts the earlier production MCS 2000 control heads to incorporate the replaceable control head pushbutton feature.

---

**Applicability**

Replaceable pushbutton retrofit kit, Motorola Kit Number REX4460( ), is applicable only to MCS 2000 Model I control heads.

---

**Identifying  
Retrofitable  
Control Heads**

The earlier production Model I control heads that are retrofitable can be identified by the kit number HCN1091( ) marked on a paper tag located on the bottom front edge.



---

## Contents of Retrofit Kit

The retrofit kit contains the following two components:

Motorola Part Number	Description
3805235Z04	Pushbutton, size F, rocker type with up and down arrows
7505240Z01	Keyweb

**NOTE:** Replaceable pushbuttons are not included with keyweb kit. Refer to Appendix A3 in MCS 2000 Installation Instructions Manual, Motorola Publication Number 68P02058U20-E, for part numbers, ordering information, and installation instructions for the replaceable pushbuttons.

---

## Keyweb Installation Procedure



### Caution

Before proceeding with this section, read and understand section titled Safe Handling of CMOS Devices at end of this publication.



### Caution

Be certain that vehicle battery or base station power supply is disconnected from radio before proceeding with installation of retrofit kit.

## Detaching Control Head from Radio Body or Back Housing

1. Disconnect microphone from control head and set it aside in a safe place.
2. Detach control head from radio body as follows:

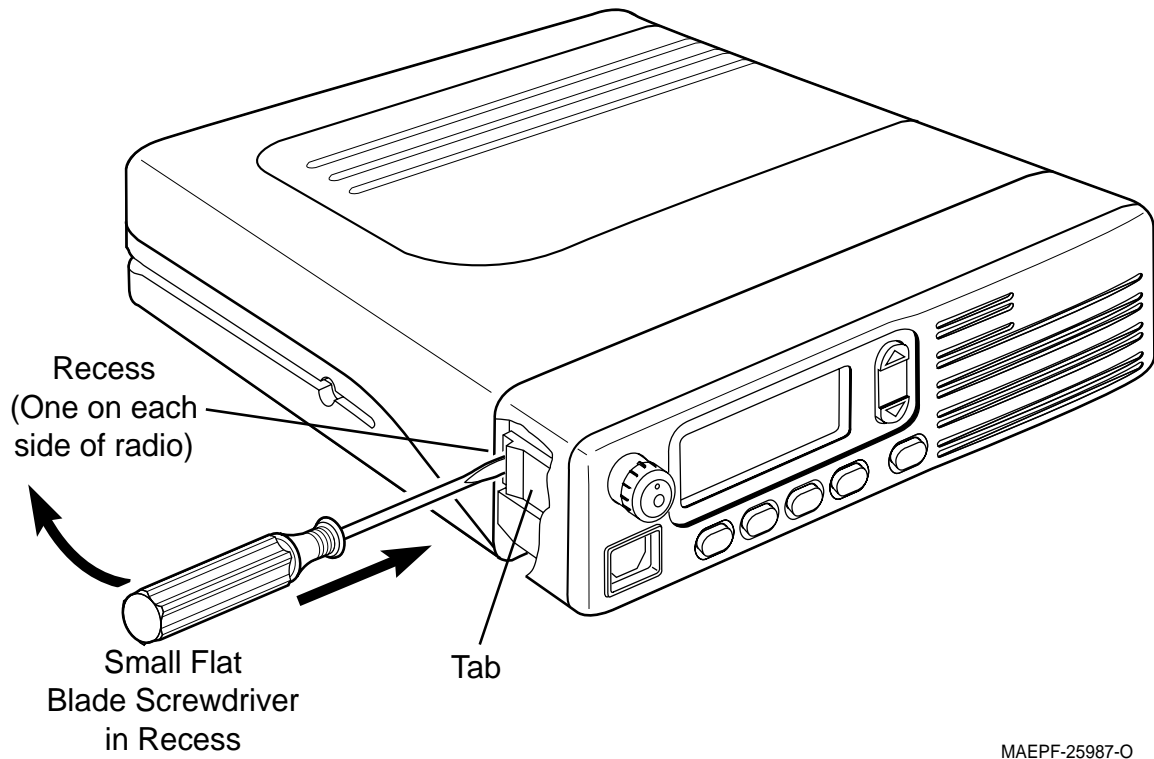

MAEPF-25987-O

*Figure 1. Inserting Screwdriver Blade into Recess Between Radio Body And Control Head Housing*

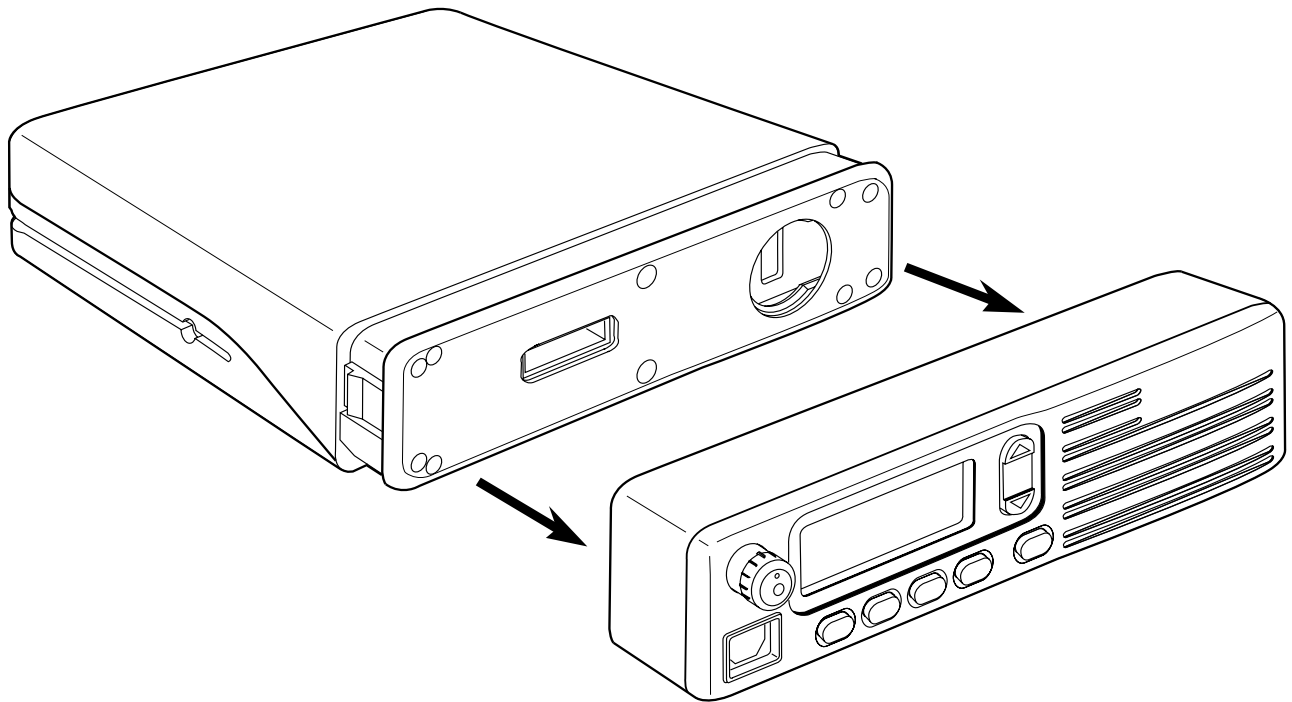

MAEPF-25988-O

*Figure 2. Removing Control Head From Radio Body*

## Dash Mount Radios Only

*NOTE:* Radio body has two snaps, one on each of its short sides. These snaps hold control head housing to radio body.

1. Refer to Figure 1 on page 3. Then, on either side of radio, insert tip of a small flat-blade screwdriver or similar tool into recess between radio body and control head housing.



### Caution

When performing steps 2 and 3, be very careful to avoid bending or otherwise damaging connector pins on back side of control head.

2. While pulling on control head housing in a direction away from radio body, push in on screwdriver blade to deflect tab on radio body inward and thereby release control head housing from radio body.
3. Refer to Figure 2 on page 3. Then repeat steps 1 and 2 above on opposite side of radio and separate control head housing from radio body.

## Remote Mount Radios Only

1. Disconnect remote mount control head cable from control head by compressing sides of plug at control end of cable and pulling plug off of mating connector.

*NOTE:* Remote mount back housing on control head has two snaps, one on each of its short sides. These snaps hold back housing to control head.



### Caution

When performing steps 2 through 4, be very careful to avoid bending or otherwise damaging connector pins on back side of control head.

2. On either side of control head, insert tip of a small flat-blade screwdriver or similar tool into recess between back housing and control head.
3. While pulling on control head in a direction away from back housing, push in on screwdriver blade to deflect tab on back housing inward and thereby release control head from back housing.
4. Repeat steps 2 and 3 above on opposite side of radio and separate control head from back housing.

## Disassembling Control Head

1. Lay control head on workbench face down.

**NOTE:** Spacer that retains circuit board and loudspeaker in control head housing has eight tabs, three on each of its long sides and one on each end.

2. Grasp long sides of control head housing with hands and spread them apart just enough to release the six tabs on long sides of spacer from recesses inside of housing.
3. Insert tip of small screwdriver between one end of spacer and recess inside of housing and pry tab out of recess to remove spacer from housing. Refer to Figure 3 below.

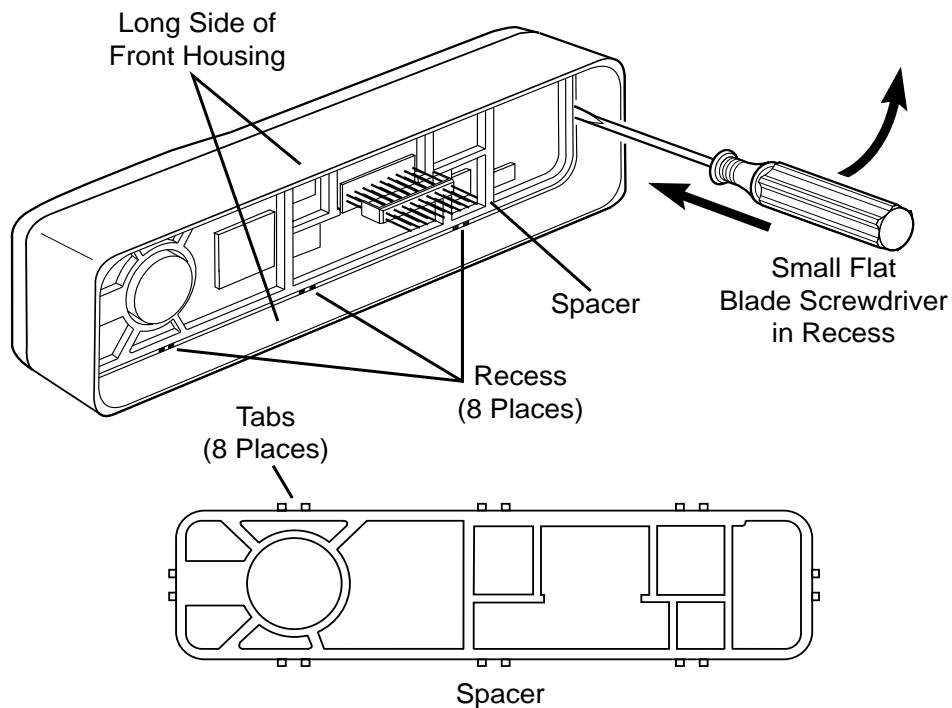

*Figure 3. Removing Spacer From Control Head Housing*



### Caution

In next step, be very careful to avoid breaking or otherwise damaging loudspeaker wires.

4. Using fingers, grab circuit board at loudspeaker end and rock it gently to disengage shaft of volume control from its knob. Then remove circuit board (with keypad attached) and loudspeaker together from housing.



## Caution

While performing next step, be careful to avoid damaging wires on loudspeaker and microphone connector.

5. Grasp flexible keypad and pull it carefully off of circuit board.

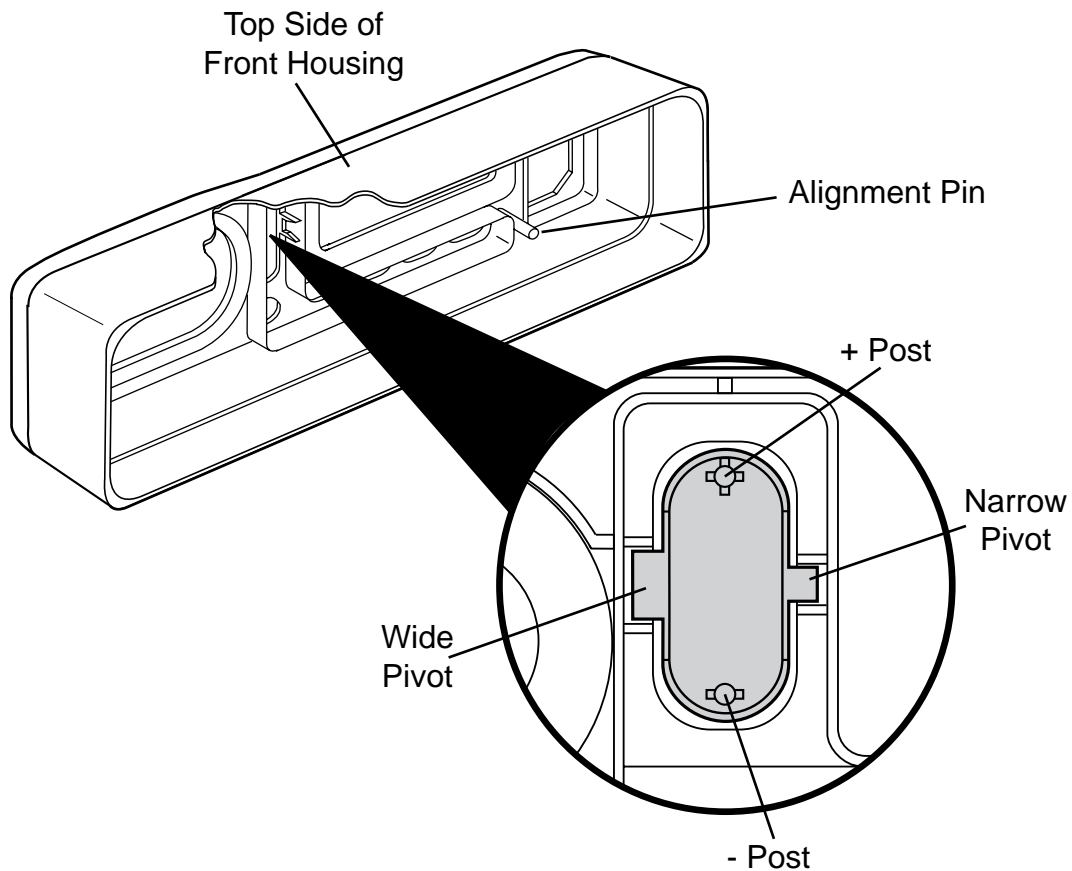

MAEPF-25986-O

*Figure 4. Installing Size F Pushbutton Into Control Head Housing*

## Reassembling Control Head

1. Refer to Figure 4 above. Then install size F rocker pushbutton, Motorola part number 3805235Z04, included in retrofit kit, into control head housing in slot next to display. The two pivots on pushbutton are different sizes (wide and narrow). The pushbutton must be installed into slot with wide pivot facing left side and + post facing top side of control head housing.
2. Install new keyweb into control head housing. Be sure that alignment pin in housing is engaged in hole in keyweb.
3. Turn volume control knob in control head housing and shaft of volume control potentiometer on circuit board fully counterclockwise.

*NOTE:* In next step, insert loudspeaker first followed by circuit board.

4. Insert loudspeaker and circuit board into control head housing. Make sure that shaft of volume control potentiometer engages completely with volume control knob.
5. Starting with tab on its loudspeaker end, snap spacer into recesses on interior of control head housing to retain circuit board and loudspeaker. Be sure all eight tabs are seated completely and correctly into recesses on interior of housing.

## Installing Control Head

### Dash Mount Radios Only

1. Place control head a short distance in front of radio body and align pins of plug on back of control head with receptacles of socket on front of radio body.
2. Slide the control head straight onto the radio body while being very careful to avoid bending or otherwise damaging pins on plug on back of control head.
3. Press control head onto radio body until both snaps on radio body engage with recesses inside short ends of control head housing.

### Remote Mount Radios Only

1. Install remote mount back housing over back of control head and snap it in place securely. Be very careful to avoid bending or otherwise damaging pins on plug on back of control head.
2. Reconnect remote mount control cable to connector on back of control head.

*NOTE:* Replaceable pushbuttons are not included with keyweb kit.

## Reidentification of Control Head

Using a fine point felt tip marker, change kit number on paper tag on bottom front edge of control head from HCN1091( ) to HCN1116( ).

## Installing Replaceable Pushbuttons

Refer to Appendix A3 in MCS 2000 installation instructions manual, Motorola Publication Number 68P02058U20-E, for part numbers, ordering information, and installation instructions for the replaceable pushbuttons.

---

## Safe Handling of CMOS Devices



### Caution

Complementary metal-oxide semiconductor (CMOS) devices are used in the MCS 2000 radios. While the attributes of CMOS are many, their characteristics make them susceptible to damage by electrostatic or high voltage charges. Damage can be latent, resulting in failures that occur weeks or months after the actual damage is done. Consequently, special precautions must be taken to prevent device damage during disassembly, troubleshooting, and repair. Handling precautions are mandatory for CMOS circuits, and are especially important in low humidity conditions. DO NOT attempt to disassemble the radio without observing the following handling precautions:

1. Eliminate static generators (plastics, styrofoam, etc.) from the work area.

2. Remove nylon or double-knit polyester jackets, roll up long sleeves, and remove or tie back loose hanging neckties.
3. Store and transport all static-sensitive devices in ESD-protective containers.
4. If at all possible, handle CMOS devices by the package and not by the leads. Prior to touching the radio, touch an electrical ground to remove any static charge that you may have accumulated.

*NOTE:* The package and substrate of a CMOS device may be electrically common. If so, the reaction to a discharge to the case can cause the same damage as touching the leads.

5. Disconnect all power from the radio before ESD-sensitive components are removed or inserted unless otherwise noted.
6. Use a static-safeguarded workstation, which can be accomplished through the use of an anti-static kit (Motorola part number 01-80386A82). This kit includes a wrist strap, two ground cords, a static-control table mat and a static-control floor mat. For additional information, refer to Service and Repair Note SRN F1052, "Static Control Equipment for Servicing ESD Sensitive Products", available from Motorola Literature Distribution, 2290 Hammond Drive, Schaumburg, IL 60173 (847) 576-2826.
7. When a static-safeguarded workstation is not available, observe the following techniques to minimize the chance of damage.
  - If a static-sensitive device is to be temporarily set down, use a conductive surface for placement of the device.
  - Make skin contact with a conductive work surface first and maintain this contact when the device is set down or picked up.
8. Always wear a conductive wrist strap when servicing the radio. The Motorola part number for a replacement wrist strap that connects to the table mat is 42-80385A59.
9. When straightening the leads and/or pins of CMOS devices, provide ground straps for the tools used for that purpose.